

Manual



Smart M 160/1 Engine

Manufacturer: Ecofly GmbH, Germany

Table of Contents

1.	Technical Concept	1
1.1.	Description	2
1.2.	Engine Layout / Dimensions	3
2.	Technical Data	5
2.1.	Principal Dimensions / Data.....	5
2.2.	Performance and Torque Curve for 60KW Engine.....	6
2.3.	Performance and Torque Curve for 74KW Engine.....	7
2.4.	Fuels / Fuel System	8
2.5.	Lubricants	9
2.6.	Cooling system and Coolant	10
2.7.	Manifold Intake	10
2.8.	Propeller Gear.....	10
3.	Operating Limits	11
3.1.	Water / Oil.....	11
3.2.	Height	13
3.3.	Manifold Temperature	13
3.4.	Manifold Pressure.....	13
3.5.	ECU / Relay Box.....	14
4.	Engine Operation.....	14
4.1.	Ignition / Warming-up	14
4.2.	Takeoff.....	15
4.3.	Landing	15
4.4.	Switching off.....	15
5.	Checks.....	15
5.1.	Daily Checks	15
5.2.	Checks after first 25hrs (in addition to 5.1.).....	16
5.3.	Checks after 100hrs / 1 year (in addition to 5.1.)	16
5.4.	Checks after 300hrs / 3 years (in addition to 5.1. & 5.3.).....	16
5.5.	Checks after 1500hrs or 15 years	17
6.	Maintenance.....	17
6.1.	Oil Circuit	17
6.2.	Air intake / Air filter (Oil in intake system?).....	17
6.3.	Compression.....	17
6.4.	Spark Plugs.....	17
6.5.	Belt Tension	17
6.6.	Extending Engine Life	17
6.7.	Torque Table	18
7.	Document Version History	18

1. Technical Concept



Our engine is a series-produced automobile engine from the smart car with belt drive for use as a stationary engine or as an uncertified power train for sports aircraft.

Engine RPM is reduced with the help of a toothed belt drive.
Car-like vibration damping is achieved by using a centrifugal clutch with soft torsion coupling.

Note:

Since this engine is a variant of a serially produced stationary engine, it does not meet the safety requirements of certified aircraft engines. The engine may therefore only be used in aircraft types where sudden engine failure does not endanger safety.

This means that the glide and landing characteristics of the aircraft must not be affected by engine failure, proof of which must be produced during aircraft certification.

Therefore, aircraft equipped with this engine must only be flown over such terrain and at altitudes and speeds so that in the event of sudden engine failure, safe landing is always possible, responsibility for which rests with the pilot.

Local regulations may apply. For Germany, see Civil Aviation Act (Luft VO) § 6.

The user acknowledges by signing below that engine failure is possible at any time because the engine is used for a purpose other than designed.

Place.....

Date:.....

Signature:.....

Furthermore, any modifications to the engine and/or drive pose potential safety risks. As such, distributors are advised to not undertake any changes prior to qualified engineering analysis and exhaustive testing!

Any irregularities, anomalies and damage must be immediately reported to the distributor!

Signature:.....

1.1. Description

- o 3-cylinder series engine with turbocharger; 60KW / 74KW
- o Fully electronic sequential injection
- o Lambda sensor controlled 3-way catalytic converter integrated into muffler (optional)
- o Electronic knock control using knock sensor
- o Power control using redundant potentiometer and e-gas
- o Dual ignition for maximum smoothness (single-circuit)
- o Manifold pressure controlled by variable valve timing, intercooler
- o Water-cooled turbocharger housing with pressurised lubrication
- o Thermostat-controlled water cooling
- o Oil circuit with wet sump
- o Overhead camshaft with maintenance-free chain drive
- o Maintenance-free valve control with hydraulic valve-play compensators
- o All-aluminium crankcase
- o Belt-driven water pump and alternator
- o Electrical starter
- o Electrical fuel pump
- o Electronic engine control unit (ECU) with relays and 2 sets of cables

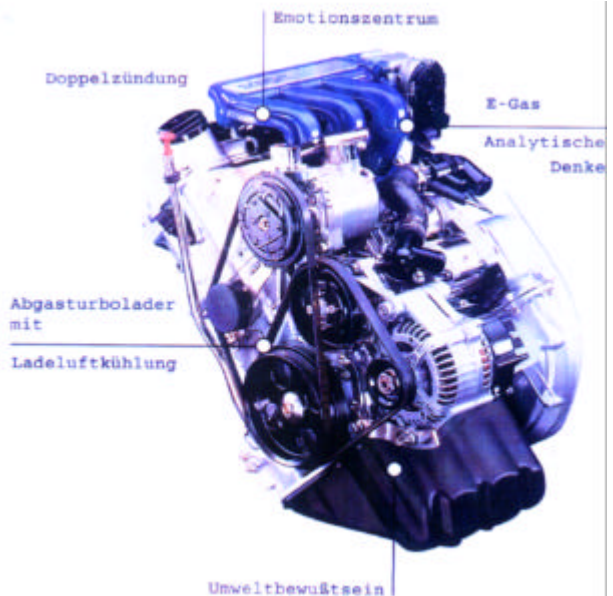

- o Flanged gearbox with bearing-mounted drive shaft
- o Toothed belt drive with adjustable belt tension
- o CNC machined propeller bearing and shaft
- o Centrifugal clutch with metal bushings to reduce torsional vibration
- o Elastically suspended mounting plate for sensors, relay box and ECU
- o 4-point engine mount

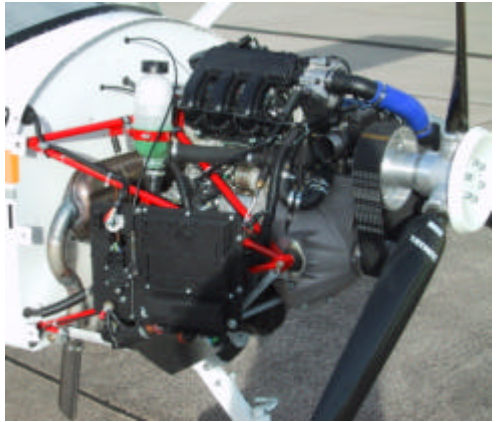

1.2. Engine Layout / Dimensions

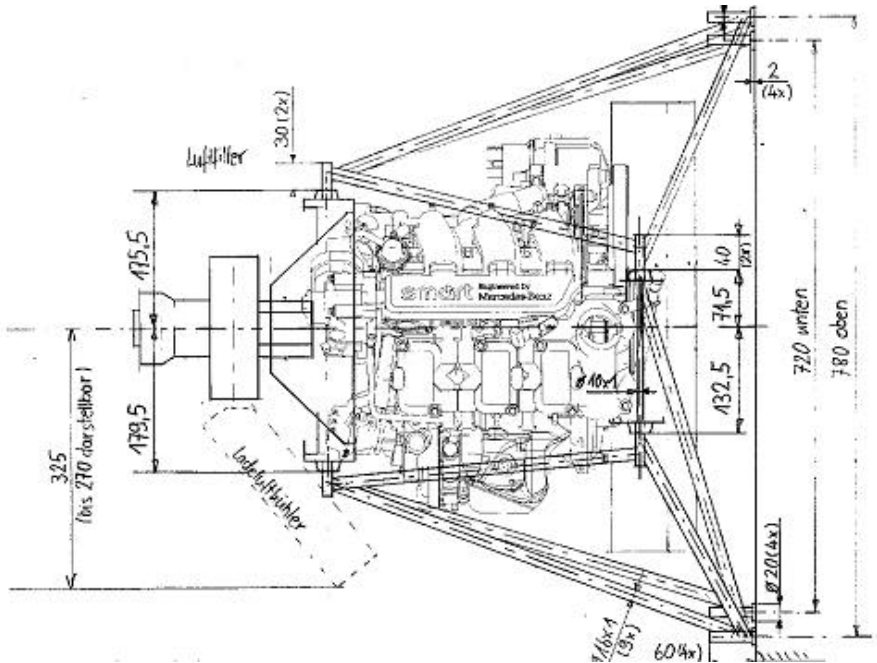

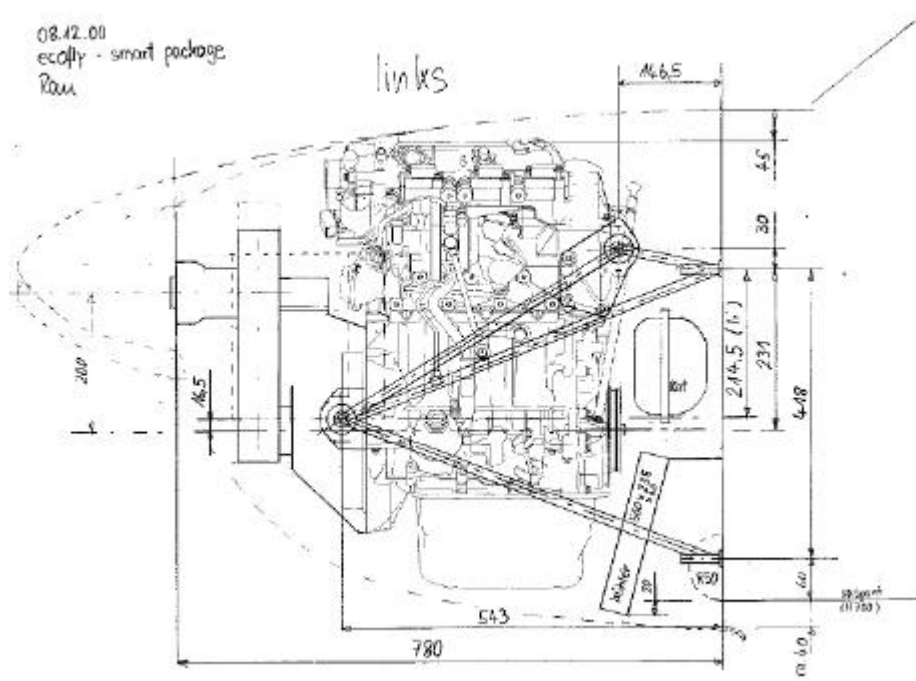

2. Technical Data

2.1. Technical Data / Key Features

	60 KW	74 KW
Capacity (cm ³)	698	
Stroke / Bore (mm)	68 / 66	
Compression ratio	9.5 (-0.4) : 1	
Cylinders / Valves	3 cylinders; 2 valves per cylinder	
Spark plugs (per cylinder)	2	
Engine weight per DIN (kg)	57	
Max. torque (Nm)	110 at 2000 – 4750 RPM	130 at 2500 – 5300 RPM
Max. power output (kW)	60 at 5250 RPM (continuous running)	74 at 5600 RPM (continuous running)
Max. continuous RPM	5800 RPM	
Max. short-time RPM	6000 RPM	
Max. manifold pressure (bar)	0.9 (+ 0.1 / - 0.2)	1.3 (+ 0.1 / - 0.1)
Charge air control	Map-guided	
Oil pump	Chain-driven, external gear pump; wet sump	
Ventilation	Integrated full and partial load ventilation	
Fuel injection / injection pressure	Bosch EV6 / 3.8 bar via intake manifold (max. 4.8 bar)	
Fuel	Min. RON 95 (super unleaded)	
Lambda sensor	Bosch LSF4	
Anti-knock control	Electronic, adaptive; 1 knock sensor	
Max. permissible turbocharger RPM	240 000	
Max. exhaust temperature	950°C (at turbocharger inlet), short-time 980°C	
Engine Diagnostics	Diagnostics module to read stored errors	

2.2. Performance and Torque Curve for 60KW Engine

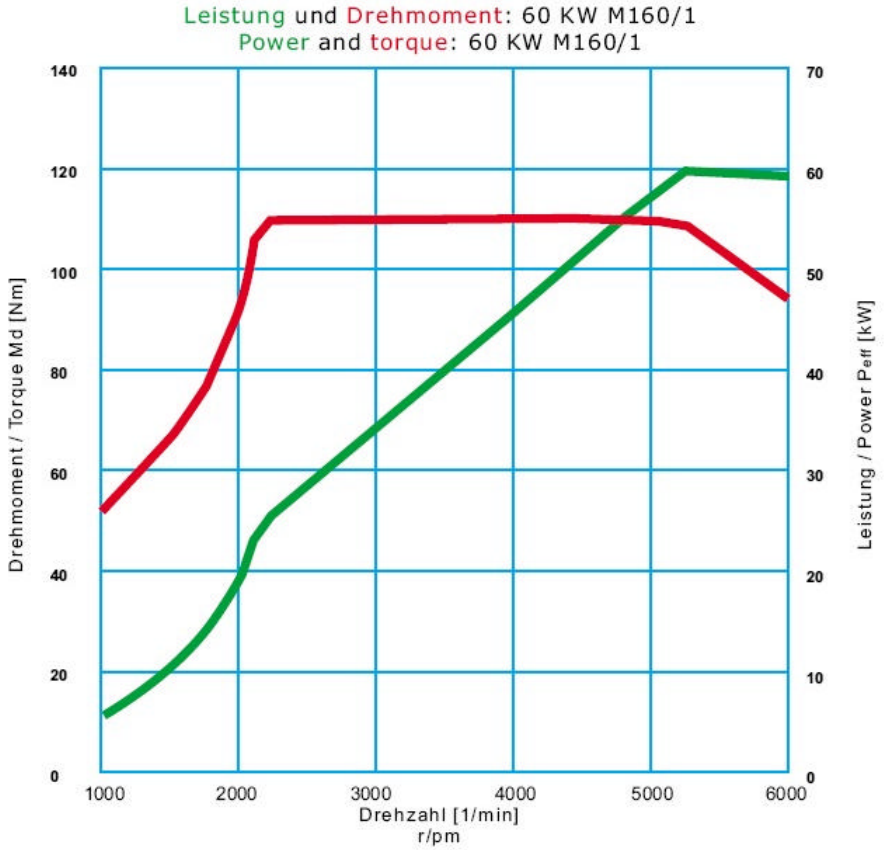

2.3. Performance and Torque Curve for 74KW Engine

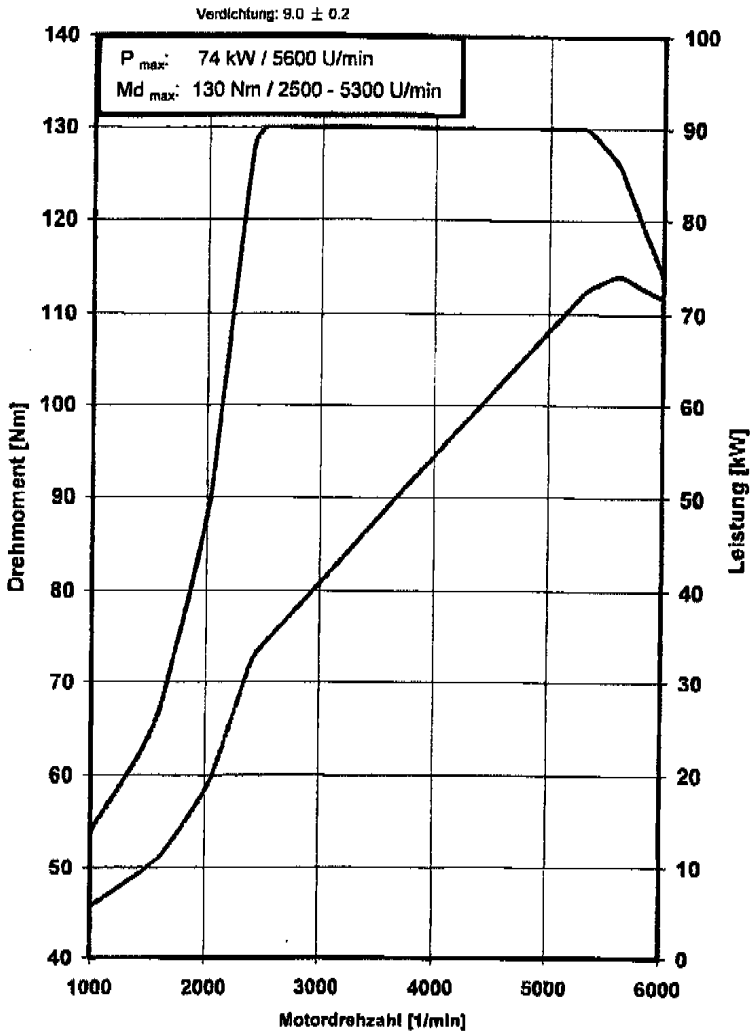

2.4. Fuels / Fuel System

Use only unleaded, min. 95 octane fuel (unleaded Super = standard automotive fuel). Do not use any fuel additives!

Remarks:

- o Leaded fuels damage not only the catalytic converter but also the lambda sensor! The general rule also for engines not fitted with a catalytic converter is therefore: **do not use leaded fuel!**
- o In case only Normal unleaded fuel is available, it can be used in exceptional cases provided maximum power is reduced to 80% (the knock control system automatically adjusts the ignition angle, minimising the risk of engine damage).
- o Recommended optionally:
 - o Unleaded Super – Plus (RON 98): at very high ambient temperatures and limited cooling of charge air, this fuel grade might even result in slightly higher performance.
 - o We also recommend sulphur-free fuels such as Shell Optimax (RON 99) (very environment-friendly and extremely knock-resistant)
- o All other fuels, even aviation-grade fuels will cause irreparable damage to the engine sooner or later!
- o Injection valves are susceptible to clogging due to fuel impurities, so use only filtered fuel and check/replace fuel filter at regular intervals.
- o A noisy fuel pump may be indicative of a clogged fuel filter: replace fuel filter!
- o Take special care when working with or checking the fuel system.
- o Guide all fuel lines away from heat sources so as to protect them from thermal fatigue. Insulate fuel lines against heat where necessary.

2.5. Lubricants

The oil tank has a capacity of **about 3.2l**.

Replace the oil filter when changing the oil. Use suction to withdraw spent oil completely.

Ecofly will install an oil bleed screw upon request.

The difference between the maximum and minimum oil level amounts to **about 0.5l**.

Note: While topping up oil, ensure that the oil level NEVER exceeds the max. level indicated on the dip stick.

Withdraw excess oil by suction if necessary.

The air-exhaust system of this engine is sensitive to excess oil; excessive oil levels may even result in irreparable damage to the engine!

Minimum requirements:

Use only branded oils of **API grade “SG”** and higher.

Recommended:

Semi-synthetic or synthetic oils are recommended.

The best oils currently on the market are classified “SJ” (API).

The best oil you can use for this engine will meet the current Mercedes-Benz Specification 229.3 (includes 229.1).

We take an excerpt from MB Specification 229.3:

Diese Öle erfüllen die scharfe Mercedes-Norm 229.3			
Addinol Extra light MV 038	Esso Ultron	Mobil Synt S	Statoil LazerWay X
Aral HighTronic	Esso Ultron (Fuel Economy)	Motor Gold Highline	Tamoil Sint Future Prestige (I)
Aral SuperSynth	Euroil Futura	Motorex Evolution 0040	Teboil Diamond Plus
Aral SuperTronic	Gulf Pride SLV	New Process Fullsynth	Unil Opal Opaljet 32 S
BP Visco 7000 Long Life	Habot -Full Synthetic	Parolin Racing Synth DC	Veba Virada Top Leichtlauf
Castrol Formula SLX	Igol Process	Pentospeed	Motoroil
Castrol TXT E.D.I. tec	Liqui Moly Synthoil Longlife	Q8 Formula Special	Veedol Powertron
Castrol TXT Softec Plus	Mobil 1	Shell Helix Diesel Ultra	Veedol Syntron
DEA Ultec SYN-T	Mobil 1 Turbo Diesel	Shell Helix Ultra	Wintershall VVA 1 eco plus

The viscosity class must be selected according to the temperature range:

15W – 40 should usually be adequate for most applications.

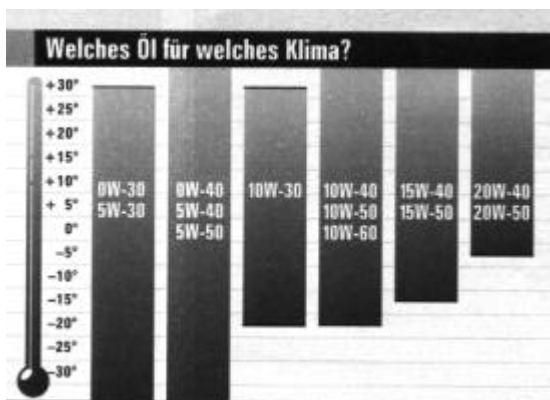

2.6. Cooling System / Coolant

The coolant is a 50:50 mixture of water and antifreeze/anticorrosive fluid.

A 50:50 mixture provides frost protection down to -37°C.

At temperatures as low as -45°C, increase the ratio of the antifreeze /anticorrosive fluid to 55% but not higher, since otherwise heat drain will be impeded.

Use only antifreeze/anticorrosive fluids recommended by Mercedes-Benz. For further information, contact the nearest Mercedes-Benz or smart service station. In the event of coolant loss, determine cause, correct and refill as necessary. At the time of refilling, top up with the recommended ratio of water and anti-freeze/anticorrosive fluid.

Completely replace the coolant every 2 years.

Since coolant temperature is thermostatically controlled, do not cover the cooler in winter!

2.7. Manifold Intake

Ensure that the air taken in is as cool as possible.

If necessary, take special measures to ensure that air taken in is not inadvertently preheated by the cooler or the exhaust.

Since carburettor icing cannot occur in this engine by design (being an injection system) preheated air is not merely superfluous, it actually reduces engine performance!

If the intake temperature is too high, the ECU will automatically reduce engine power output, WHICH MAY GIVE RISE TO DANGEROUS SITUATIONS.

Use only suitable air filters. Check, clean or replace the air filter at regular intervals.

Ensure that all water entering the air intake is drained completely ahead of the air filter.

Ensure that no rubber particles from the belt drive are sucked in.

Optimum charge air cooling must be ensured whenever the engine is operational. **NEVER cover the intercooler fully or even partially in winter.**

2.8. Propeller Gear

The transmission ratio is 2.1 : 1.

Toothed belt: HTD-(Powergrip GT2) 8M; 60mm width.

Check belt tension at regular intervals. When the engine is cold, the belt should yield 5-10mm when pressed down at the centre of the exposed length.

If necessary, insert washers to adjust the distance of the propeller axle from the drive shaft.

Note:

- o Ensure that the drive axes are perfectly parallel.
- o Misalignments will provoke damage
- o NEVER assemble the propeller axle without locating pins.
- o Do not insert any spacers to extend the engine-propeller distance: this will increase the bending load on the gears beyond permissible limits!

Note that a new belt will initially lose some rubber; this is not indicative of unusual wear.

Check for play on the bottom bearing by pressing the belt down with a finger (in case of damage, the play can be felt).

The same applies to the front and rear propeller bearings. Push against the propeller to check that there is no radial play.

To increase comfort, the engine is fitted with a centrifugal clutch (which engages at 1600 – 2000 RPM) and a soft, metal torsion coupling.

Never get out of an aircraft when the engine is idling, not even when the propeller has stopped turning! Always switch off the engine before getting out of the cockpit!

3. Operating Limits

While the engine is rated for maximum power output of 60/74KW, we recommend that the engine power is suitably adjusted for cruise flight to conserve fuel.

Note that the engine is completely unsuited for aerobatic manoeuvres! Do not conduct stall exercises!

Aerobatic manoeuvres will damage the engine!

Avoid any critical RPM at which the natural frequency of the propeller and cockpit cell resonate.

Maximum permissible engine rating amounts to 5800 RPM.

3.1. Water / Oil

Maximum permissible water temperature is 105°C.

Water temperature of 110°C is permissible for short times.

If the water temperature increases, the ECU will automatically reduce engine power output.

Minimum water temperature for takeoff amounts to 60°C.

Maximum permissible oil temperature is 140°C.

Oil temperature of 150°C is permissible for short times.

Minimum oil temperature for takeoff amounts to 60°C.

The diagram below indicates normal temperatures against RPM.

The minimum permissible oil pressure is a function of the oil temperature and RPM.

See diagram below (applies to engines when new)

In the engines that have been in operation for longer periods, the indicated values can be lower by about 10%. For instance:

- At 2000 RPM: Min. oil pressure 2.0 bar (oil temperature 110°C); if oil temperature is higher, oil pressure will be lower
- At 4000 RPM: Min. oil pressure 2.9 bar (oil temperature 125°C); if oil temperature is higher, oil pressure will be lower
- At 5500 RPM: Min. oil pressure 3.3 bar (oil temperature 135°C); if oil temperature is higher, oil pressure will be lower

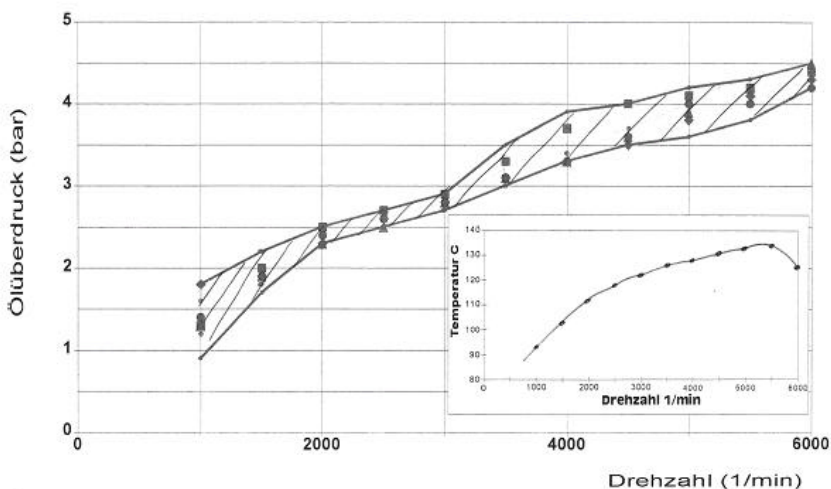

3.2. Height

The turbocharger is configured such that the engine will deliver 60/74KW of power up to 2500m height.

Reduce power setting above 2400m so that the turbocharger does not exceed its maximum rotational speed.

As a thumb rule:

Reduce power by 50 RPM (i.e. by about 1%) for every 100m increase in height above 2400m. For example, at 3000m, reduce power by 300 RPM ($6 \times 50 = 300$). We recommend that you reduce the RPM even further above a certain height.

3.3. Manifold Temperature

Maximum permissible manifold temperature is 45°C at 20°C ambient temperature.

The lower the manifold temperature, the better will be engine performance due to the more favourable ignition angle and higher air density.

Engine power output is lower at 45–55°C while at 60°C, the ECU will sharply lower manifold pressure!

Use Super Plus (98 RON) fuel at very high ambient temperatures to prevent the anti-knocking system from scaling back ignition.

If necessary, use an electric fan to support cooling (in cases where air flow is poor, e.g. in trike applications).

In general, allow uniform air flow on the surface of the intercooler!

3.4. Manifold Pressure

Manifold pressure at full power setting must show between 0.7 and 1.0 bar (60 KW) or 1.2 and 1.4 bar (74 KW).

The SMART-MIP (engine monitoring unit) which shows total pressure, will indicate at full load 1.7 to 2 bar (60 KW) and 2.2 to 2.4 bar (74 KW).

If pressure is not high enough, check system for leaks. If no obvious faults are found, contact the service centre and have the turbocharger recalibrated.

If the manifold pressure exceeds 1.0 bar (60 KW) or 1.4 bar (74 KW), contact the service centre and have the turbocharger recalibrated.

3.5. ECU / Relay Box

Install the ECU so that the rear of the ECU is ventilated by cool ambient air. This arrangement is necessary to drain the heat from active components.

Max. temperature on ECU housing: 90°C.

Install the relay box and contacts such that they are protected from spray.

Moisture will cause contact problems!

4. Engine Operation

Read the manual before operating the engine!

Note:

Always adjust engine RPM so that the engine runs smoothly.

Make sure that the centrifugal clutch does not “drag”. Avoid the 4100-4200 RPM range as engine operation is not as smooth as at other speeds.

4.1. Ignition / Warming-up

Complete the daily check (see 5.1) before switching on the engine.

To start engine:

Fuel valve:	Open
Throttle:	Idle position (fuel/air mixture is controlled electronically)
Main switch:	On
Ignition:	On
Starter:	Operate

As soon as the engine starts, throttle up sufficiently so that the engine runs smoothly in conjunction with the resonance frequency of the cell/propeller.

Never operate the engine for long periods at low RPM (with stationary propeller) so as to provoke overheating situations.

If water temperature touches 100°C on ground, increase engine RPM to 2000 for better cooling!

Allow engine to warm up at about 2000 RPM.

After 2 minutes, engine RPM can be raised to 2500 RPM until all temperatures have reached minimum operating temperatures (water: min. 60°C, oil min 60°C).

After taxiing to the holding point, apply brakes and set the engine briefly to full power. Check that manifold pressure increases to between 0.7-1 bar (60KW) or 1.2 to 1.4 bar (74 KW). The SMART-MIP will indicate total pressure, so at the time of this check, it should indicate 1.7 to 2 bar (60 KW) or 2.2 to 2.4 bar (74 KW).

If manifold pressure does not increase, abort takeoff immediately, determine the cause of the fault and correct.

Monitor oil pressure at all times.

4.2. Takeoff

Always set full power for takeoff.

In addition to observing temperatures, monitor especially the indicated oil and manifold pressure.

Leave engine at full power until you reach safe flying altitude; since the engine regulates itself, it is not necessary to power down!

4.3. Landing

Set engine speed to 2000 RPM during landing approach. The centrifugal clutch is fully engaged at this speed and the propeller will show better retarding characteristics.

4.4. Switching off

After landing and taxi in, all engine components would have cooled down sufficiently so that the engine can be switched off without taking any special measures.

The turbocharger has a self-regulating thermosyphon to cool the exhaust manifold in order to prevent oil coking.

After stationary full-load operation, it is sensible to allow the engine to run for two minutes (with propeller engaged at about 2000 RPM) to allow it to cool down.

5. Checks

5.1. Daily Checks

- o Remove cowling completely (top and bottom halves)
- o Check engine frame and bearing seats (gearbox) for cracks
- o Check bearing washers for cracks, replace if necessary
- o Turn the drive belt around once and check for damage (outside and inside)
- o Check drive and coolant lines as well as connections for coolant loss; correct as necessary
- o Check drive for oil leaks; correct all leaks immediately
- o Ensure that oil level is between Min. and Max. markings on the dip stick; top up oil if necessary. DO NOT OVERFILL!
- o Check fuel system for leaks
- o Check all cables for abrasion damage; check proper seating of plugs
- o Check proper functioning of the centrifugal clutch
(Clutch should engage at 1800 ± 200 RPM)

5.2. Checks after first 25hrs (in addition to 5.1.)

- o Check the entire power train for loose or missing nuts and screws. Replace or tighten as necessary.
- o Check belt, belt tension, propeller drive and propeller bearings
- o Check air filter
- o Change oil, renew oil filter
- o Clean and renew fuel filter if necessary

5.3. Checks after 100hrs / 1 year (in addition to 5.1.)

- o Check the entire power train for loose or missing nuts and screws. Replace or tighten as necessary
- o Coat engine bearing and other rubber components with a rubber-care fluid
- o Check belt, belt tension, propeller drive and propeller bearings
- o Check belt tension: must yield 5-10mm in a cold engine when pressed down with a finger; adjust if necessary
- o Change oil, renew oil filter
- o Renew fuel filter
- o Carefully check fuel system and lines for signs of brittleness; check all guides, joints and connectors, renew ageing components where necessary
- o Clean air filter; renew if necessary
- o Check for dirt in the interstices between cooling fins of the intercooler, clean carefully

5.4. Checks after 300hrs / 3 years (in addition to 5.1. & 5.3.)

- o Renew spark plugs
- o Check compression
- o Renew coolant
- o Until and such time long-term tests are concluded, we strongly recommend renewing the belt to be on the safe side.
Contact Ecofly GmbH.
- o after completion of long-term tests we expect a renewal of the belt every 600h (check in advance with Ecofly GmbH)

5.5. Checks after 1500hrs or 15 years

We recommend full engine overhaul after 1500hrs. Contact your engine service station.

Since these engines are produced in large numbers, it may be cheaper to buy a new engine (crankcase with power plant and cylinder head) and install it along with a new e-gas unit and turbocharger.

If the belt pulleys are not severely damaged, you will only need to replace three bearings in the gearbox.

6. Maintenance

Contact Ecofly GmbH until long-term tests are concluded. If necessary, detailed maintenance instructions can be obtained from any smart-center website.

6.1. Oil Circuit

In process

6.2. Air intake / Air filter (Oil in intake system?)

In process

6.3. Compression

In process

6.4. Spark Plugs

In process

6.5. Belt Tension

In process

6.6. Extending Engine Life

In process

6.7. Torque Table

All M6 in aluminium:	12 ± 1 Nm
All M8 in aluminium:	20 ± 1,6 Nm
Engine frame strut to cylinder head:	23 ± 2 Nm
Alternator to aggregate frame:	28 ± 2 Nm
Starter to crankcase / gearbox:	20 ± 1,6 Nm
Mitnehmerscheibe to crankshaft (M10*1):	47Nm ± 2Nm, angle of twist 90°
LU Turbocharger to cylinder head (stud):	6 Nm ± 0,5 Nm
LU Turbocharger to cylinder head (M6 nut):	16 Nm ± 1 Nm
Lambda sensor in turbocharger housing:	50 Nm ± 5 Nm
Knock-sensor to crankcase:	20 Nm ± 1,6 Nm
Fuel distributor on manifold (M6):	8,5 Nm ± 0,5 Nm
Pressure sensor on manifold:	5,5 Nm ± 0,5 Nm
E-Gas Drosselklappensteller an Saugrohr:	8,5 Nm ± 0,5 Nm
Oil line to Turbo (screw M8 * 1):	10 Nm ± 1 Nm
Water line to turbocharger (M12.5 * 1.5):	19 Nm ± 1 Nm
Spark plugs:	20 Nm ± 2 Nm
Drive wheel to crankshaft extension:	180 Nm + 20 Nm
Slotted nut: drive wheel to propeller shaft:	200 Nm + 20 Nm

7. Document Version History

The current version of this document can be downloaded from www.ecofly.de.

First edition English version July 2005